

## Application of accurate rock core logging in engineering design process

ABD RASID JAAPAR

Soils & Foundations Sdn. Bhd.  
23, Jalan Desa, Taman Desa  
Off Jalan Klang Lama, 58100 Kuala Lumpur

**Abstract:** Many engineering geologists devote a significant proportion of their time to the logging of boreholes and, specifically, to the interpretation of rock cores in engineering terms. A variety of techniques have been devised for logging such cores. In Malaysia, the common practices are often inadequate in relation to modern requirements. This paper reviews the application of accurate rock core logging in rock mechanics and in engineering design process. It tries to compile some of its applications as a design aid in rock engineering. It is intended for geologists who are involved in geotechnical engineering to understand the relationship between accurate rock core logging and the design process in rock engineering. The importance and relation of accurate rock core logging on rock mass classification and its application to engineering design is highlighted.

**Abstrak:** Kebanyakan ahli geologi kejuruteraan menghabiskan sebahagian besar masa mereka untuk mengelog lubang gerek terutamanya bagi menginterpretasi teras batuan dalam istilah kejuruteraan. Beberapa teknik telah wujud untuk mengelog teras batuan. Kertas ini mengulas penggunaan pengelogan tepat teras batuan dalam mekanik batuan dan proses rekabentuk kejuruteraan dan cuba untuk mengkompilasi sebahagian penggunaannya sebagai bahan rekabentuk dalam kejuruteraan batuan. Kertas ini juga ditujukan untuk ahli-ahli geologi yang terlibat dalam kejuruteraan geoteknik untuk memahami hubungan diantara pengelogan tepat teras batuan dengan proses rekabentuk dalam kejuruteraan batuan. Kepentingan dan hubungan pengelogan tepat teras batuan terhadap pengelasan massa batuan dan penggunaannya terhadap rekabentuk kejuruteraan diperjelaskan.

### INTRODUCTION

Accurate rock core logging requires care and vigilance by the geologist in the recording of data, particularly that information which only he is able to collect. This may necessitate increased liaison between geologist, engineer and driller and tactful education of drilling staff.

This paper tries to reviews the application of accurate rock core logging on rock mechanics and in engineering design process and its will not discuss on the methodology of rock core logging in details as many manuals, standards or guidelines had been prepared for this.

### DESIGN PROCESS AND METHODOLOGIES

Bieniawski (1989) has highlighted that in a conventional geotechnical engineering design, the external loads to be applied are first determined and a material is then prescribed with appropriate strength and deformation characteristics, following which the structural geometry is selected. In rock mechanics, the designer deals with complex rock masses, and specific material properties cannot be easily prescribed to meet design requirements. A number of possible failure modes can exist in a rock structure, so that the determination of the "material strength" is a major problem. Finally, the geometry of the structure in rock may depend on the configuration of the geological features. Hence the design in rock must include a thorough

appraisal of the geological conditions and, especially, possible geological hazards.

Hoek and Bray (1977) mentioned that a frequent mistake in rock engineering is to start an investigation with a detailed examination of rock cores. While these cores provide essential information, it is necessary to see this information in the context of the overall geological environment in which the proposed mine, road or dam site is to be located. Structural discontinuities, upon which local failure of a bench can occur, are related to the regional structural pattern of the area and it is therefore useful to start an investigation by building up a picture of the regional geology.

### WHY ACCURATE ROCK CORE LOGGING?

There is perhaps no engineering discipline that relies more heavily on engineering judgement than rock mechanics. This judgement factor is, in part due to the difficulty in testing specimens of sufficient scale to be representative of rock mass behaviour and, in part due to the natural variability of rock masses. Accurate rock core logging plays an important role as part of this engineering judgement in rock mechanics. In this respect, the real concern of accurate rock core logging is appropriately expressed by Hoek and Bray (1977), "In fact, experience suggests that attempts by engineers to set up elaborate rock classification systems and standard rock core logging forms

**Table 1.** Summary of engineering properties of igneous rock in Peninsular Malaysia (after Ibrahim Komoo, 1989).

Rock Type	Dry Density (gcm <sup>-3</sup> )	Shore Hardness	Point Load Strength Index (MPa)	Uniaxial Compressive Strength (MPa)	Brazil Tensile Strength (MPa)
Granite, P. Pinang	2.60	51.6	7.63	94.4	9.6
Granite, Kulim	2.61	71.2	-	120.9	9.6
Granite, Ampang	2.62	76.2	10.91	130.8	9.6
Granite, Kajang	2.62	72.1	10.50	114.4	10.3
Granite, Semenyih	2.61	76.6	9.85	125.6	9.3
Granite, Kulai	2.68	74.5	9.00	156.9	10.7
Granite, Tangkak	2.59	90.2	9.85	164.9	11.6
Granite, Pengerang	2.60	86.6	11.44	180.3	9.2
Granite, Kenyir	2.60	78.1	8.63	104.2	9.2
Rhyolite, Temerloh	2.63	82.4	16.54	238.7	20.2
Andesite, Temerloh	2.83	47.1	7.04	136.8	16.5
Dolerite, Temerloh	2.81	76.2	8.02	135.1	16.3
Gabbro, Kulai	2.89	60.2	7.65	140.1	10.8
Basalt I, Segamat	2.75	66.9	8.44	210.9	15.8
Basalt II, Segamat	2.78	59.0	6.90	135.4	11.3
Basalt III, Segamat	2.86	60.7	7.83	107.7	11.8
Trachyte, Air Hitam	2.62	82.5	11.42	197.2	15.7
Trachyte, Pengerang	2.68	92.5	12.37	352.8	18.3

have been remarkably unsuccessful because geologists tend to be highly individualistic and prefer to work from their own point of view rather than that decreed by someone else”.

It is apparent that the maximum potential yield of data from many boreholes were not attained and, in consequence, the benefit from drilling not fully realized. It was recognised, in part from variety of logs which are in current use, that techniques of logging are often determined by such factors as the method of drilling, type of project, cost or the client's requirement.

Malaysian practice of rock core logging for the past years basically based on a mixture of British Standard (BS5930, 1981), Geoguide of the Hong Kong Geotechnical Control Office (GCO, 1988) and Geological Society Engineering Geology Group Report (Anon, 1970). Other international guideline or methods for accurate rock core logging are International Association of Engineering Geology (Anon, 1981) and International Society of Rock Mechanics (ISRM, 1981 and 1978). There are various guidelines, standard and manual published by various organisation in the United States of America such as United States Bureau of Reclamation (USBR, 1974), American Association of State Highways and Officials (AASHTO, 1988) and United States Army Corps of Engineers (USACE, 2001). Publications from other countries in Europe or even Japan are not commonly used locally. British Standard Institution had released the latest version of BS5930 in 1999. The rock core logging section was upgraded and simplified. It is very suitable for local practice.

Most of the published method for accurate rock core logging had their own description sequence. However, the practice in Malaysia should have only one standardised scheme. Norbury *et al.* (1986) mentioned that it is important

to use only one standardised scheme of description to ensure the following:

- all factors are considered and examined in logical sequence,
- no essential information is omitted
- no matter who describes the sample, the same basic description is given using all terms in identical way,
- the description conveys an accurate mental image to the reader,
- any potential user can quickly extract the relevant information.

Directly or indirectly, all the publications highlighted that accurate rock core logging can be separate into two parts: namely descriptive logging and mechanical logging.

### Descriptive logging

Descriptive logging basically consists of material characteristics of the rock such as ‘strength’, colour, grain size, rock name, etc. The name of the rock and rock formation is important as it usually provides some knowledge of the likely range of properties and the general behaviour of a given rock type which are useful for preliminary assessment.

The association between rock type and possible feature, e.g. karst features in limestone or boulders in a granitic area can be useful in planning and design requirements as well as construction control. The texture and rock fabric are useful for gauging the behaviour and strength anisotropy. There are local researchers who have published data for specific rock types and formations such as for igneous rock in Peninsular Malaysia as presented in Table 1 by Ibrahim Komoo (1989).

In Malaysia, the need to classify rock characteristics in term of weathering grades is very important. The different

**Table 2.** Porosities of some typical rocks showing effects of age and depth. Data from Clark (1966) and Brace and Riley (1972).

Rock	Age	Depth	Porosity (%)
Mount Simon sandstone	Cambrian	13,000 ft	0.7
Nugget sandstone (Utah)	Jurassic		1.9
Potsdam sandstone	Cambrian	Surface	11.0
Pottsville sandstone	Pennsylvanian		2.9
Berea sandstone	Mississippian	0-2000 ft	14.0
Keuper sandstone (England)	Triassic	Surface	22.0
Navajo sandstone	Jurassic	Surface	15.5
Sandstone, Montana	Cretaceous	Surface	34.0
Beekmantown dolomite	Ordovician	10,500 ft	0.4
Black River limestone	Ordovician	Surface	0.46
Niagara dolomite	Silurian	Surface	2.9
Limestone, Great Britain	Carboniferous	Surface	5.7
Chalk, Great Britain	Cretaceous	Surface	28.8
Solenhofen limestone		Surface	4.8
Salem limestone	Mississippian	Surface	13.2
Bedford limestone	Mississippian	Surface	12.0
Bermuda limestone	Recent	Surface	43.0
Shale	Pre-Cambrian	Surface	1.6
Shale, Oklahoma	Pennsylvanian	1000 ft	17.0
Shale, Oklahoma	Pennsylvanian	3000 ft	7.0
Shale, Oklahoma	Pennsylvanian	5000 ft	4.0
Shale	Cretaceous	600 ft	33.5
Shale	Cretaceous	2500 ft	25.4
Shale	Cretaceous	3500 ft	21.1
Shale	Cretaceous	6100 ft	7.6
Mudstone, Japan	Upper Tertiary	Near surface	22-32
Granite, fresh		Surface	0 to 1
Granite, weathered			1-5
Decomposed granite (Saprophyte)			20.0
Marble			0.3
Marble			1.1
Bedded tuff			40.0
Welded tuff			14.0
Cedar City tonalite			7.0
Frederick diabase			0.1
San Marcos gabbro			0.2

weathering grades have significant impacts on the geometry and design of cut slopes for instance. The weathering profile is also known to have a significant impact on potential failure surface, mode of failure, groundwater hydrology and erosion characteristics.

Porosity of rocks generally decreases with age and with depth below the surface as presented in Table 2 (Clark, 1996; Brace and Riley, 1972). The effect of moisture content on the uniaxial compressive strength of the rock is greatest when the porosity of rock is high.

### Mechanical logging

Mechanical logging basically deals with discontinuities since in rock mechanics, discontinuities are a major controlling factor other than strength and weathering effect.

The mechanical behaviour of discontinuities in rock may have direct importance in many civil engineering projects. The stability of rock slopes and tunnel walls are often governed by the shear strength of the discontinuities and not the strength of the intact rock core. The strength and stiffness of the interface between rock blocks can also have important influence on the mechanical behaviour of the overall rock mass. The major factors governing the

**Table 3.** Classification and correlation of rock with RQD (after Deere and Deere, 1988).

Classification	RQD	$\frac{E_{\text{field}}}{E_{\text{lab}}}$
Very Poor	0 - 25	0.2
Poor	25 - 50	0.2
Fair	50 - 75	0.2 - 0.5
Good	75 - 90	0.5 - 0.8
Excellent	90 - 100	0.8 - 1.0

behaviour of discontinuities are roughness, presence of infill, weathering, etc.

The classical rock quality designation (RQD) index which were introduced almost 40 years ago in 1964 by D.U. Deere (Deere *et al.*, 1967) as index of rock quality is a part of mechanical logging.

The RQD is a modified core-recovery percentage which incorporates only sound pieces of core that are 100 mm (4 in) or greater in length. This quantitative index has been widely used as a flag to identify low-quality rock zones which deserve greater scrutiny and which require additional borings or other exploratory works. The relationship between RQD index and the engineering quality of the rock (Deere and Deere, 1988) presented in Table 3.

RQD has been extensively used for civil engineering design and appraisal and some of the usage are presented below:

- an indication of the degree of fracturing
- a quick assessment of the quality of an in situ rock mass by an examination of a borehole record
- can be used to provide a correlation between intact rock strength and in situ strength of rock mass and deformation

### TRANSLATING ACCURATE ROCK CORE LOGGING TO ROCK MASS CLASSIFICATION SYSTEM

Accurate rock core logging can be used for identifying and classifying two established rock mass classification systems. They are Q-system introduced by Barton *et al.* (1974) and Geomechanics Classification or better known as Rock Mass Rating system (RMR) introduced by Bieniawski (1973). Correlation between RMR system and Q index based on many case histories are presented in Figure 1 by Bieniawski (1976). However, this paper will only discuss the relationship between accurate rock core logging and the above classification systems.

#### Q-system

Q-system of rock mass classification was developed in Norway. This system is for facilitating the design of tunnel support. The Q-system is based on a numerical assessment of rock mass quality using six different parameters:

- i. Rock quality designation (RQD)
- ii. Number of joint sets ( $J_n$ )
- iii. Roughness of the most unfavourable joint or discontinuity ( $J_r$ )
- iv. Degree of alteration or filling along the weakest joint ( $J_a$ )
- v. Water inflow ( $J_w$ )
- vi. Stress condition or stress reduction factor (SRF)

These six parameters are grouped into three quotients to give overall rock mass quality,  $Q$  as follows:

$$Q = RQD/J_n \times J_r/J_a \times J_w/SRF$$

The three terms of the  $Q$  index gives crude measurements block size (i.e.  $RQD/J_n$ ), inter block shear strength ( $J_r/J_a$ ) and active stress ( $J_w/SRF$ ) respectively. All the six parameters can be identified from accurate rock core logging prior to the construction of tunnels. The fifth and sixth parameters can be estimated based on visual examination. However, more accurate estimation can be made should there be any testing carried out in situ such as water pressure testing.

### Rock Mass Rating (RMR) system

Rock Mass Rating (RMR) system has a values of between 1 and 100. The values assigned are based on 5 parameters and 1 parameter depending on use. The rock mass is then classified based on total rating. The following parameters are used to classify a rock mass using the RMR system:

- Uniaxial compressive strength of the rock material
- Rock quality designation (RQD)
- Spacing of discontinuities
- Condition of discontinuities
- Groundwater conditions
- Orientation of discontinuities

### Applications of rock mass classification

Many application of rock mass classification system have been reported by Bieniewski (1989). Other than the

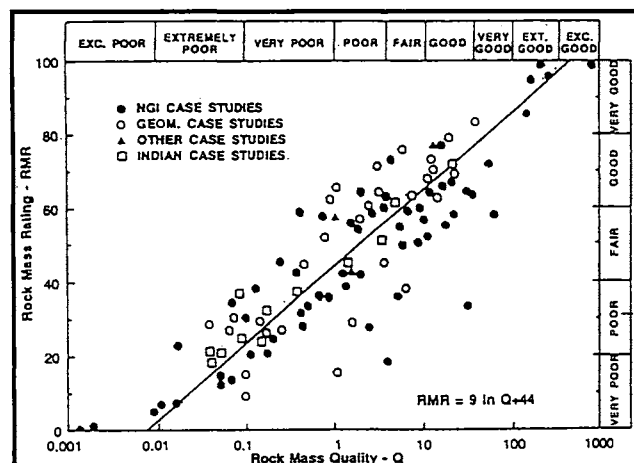

Figure 1. Correlation between the RMR and  $Q$ -index (after Bieniawski, 1976).

major used in tunnelling and mining, the classification system has also used for the following:

- assessing underground condition (Vallejo, 1983)
- estimating rock mass strength (Hoek and Brown, 1988), Robertson (1988), Serafin and Pereira (1983) as presented in Figure 2, Laubscher (1984), Stille *et al.* (1982) and Yudhbir (1983).
- estimating rock mass modulus (Bieniewski, 1978), Serafin and Pereira (1983) and Barton (1983) as shown in Figure 3.
- assessing rock slope stability (Romana, 1985)
- assessing the excavatability and rippability (Weaver, 1975) with the inclusion of seismic velocity as parameter, Smith (1986), Singh *et al.* (1986), Kirsten (1982) and Abdul Latif and Cruden (1983) as shown in Figure 4.

### ACCURATE ROCK CORE LOGGING AND FOUNDATION ON ROCK

The allowable foundation loads on rock will be the function of the properties of intact rock as well as the properties and spacing of discontinuities. The design of foundations in rock generally involves the consideration of the following two classes of foundation:

- foundations bearing directly on rock
- foundation socketed into rock.

Ooi (2002) had compiled some useful references for these purposes. For foundations bearing directly on rock, data from accurate rock core logging such as the presence of weak layers, discontinuities, weathering and structural geology is very important as a high allowable bearing pressures in rocks may be reduced by any of the above. The size of footing in relationship to the spacing of the discontinuities and the presence of weak layers within the

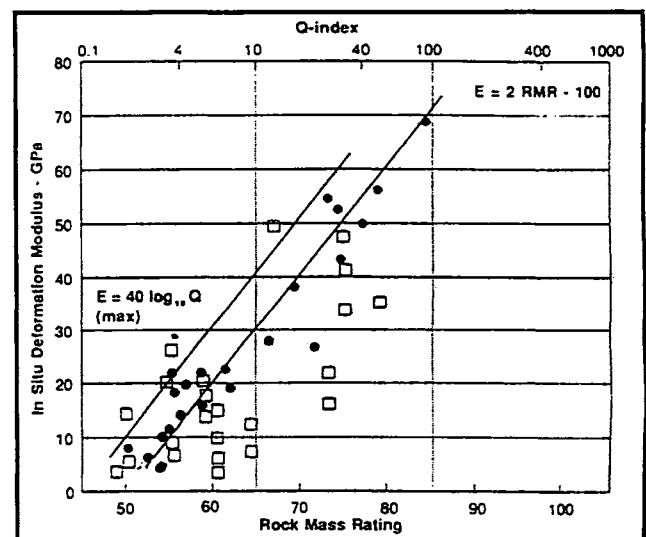

Figure 3. Estimation of insitu modulus of deformation from two classification methods. squares represent  $Q$  case histories, dots are RMR cases (after Barton, 1983).

zone of influence may effect the capacity and settlement performance.

BS8004 (BSI, 1986) gives a table of presume allowable bearing values for strong unweathered rocks (Table 4). However, the code emphasis that the values should only be used for preliminary design and review may be necessary. The code also presents the allowable bearing pressures for weak and broken rocks for pad foundations subjected to settlement of less than 0.5% of the foundation width (Fig. 5). The code highlights that the compressibility of the rock mass is related to the intact rock strength, the lithology, the frequency and nature of discontinuities. All these data can be obtained from an accurate rock core logging. Hence, to determine the allowable bearing pressures, rocks have been placed into groups of similar modulus ratio (Young's modulus/uniaxial compressive strength) as presented in

Rock Mass Properties					
RMR	100-81	80-61	60-41	40-21	<20
Rock class	I	II	III	IV	V
Cohesion, kPa	>400	300-400	200-300	100-200	<100
Friction, deg	>45	35-45	25-35	15-25	<15
Modulus, GPa	>56	18-56	5.6-18	1.8-5.6	<1.8
Shear Strength of Rock Material					
Cohesion, MPa	>25	15-25	8.5-15	4.5-8.5	<4.5
Friction, deg	>65	55-65	48-55	41-48	<41
Frictional Shear Strength of Discontinuities, deg					
Rating for Condition of Discontinuities:	30	25	20	10	0
Completely dry	45	35	25	15	10
Damp	43	33	23	13	<10
Wet	41	31	21	11	<10
Dripping	39	29	19	10	<10
Flowing	37	27	17	<10	<10

Figure 2. Geomechanics classification for rock foundations. shear strength data (after Serafin and Pereira, 1983).

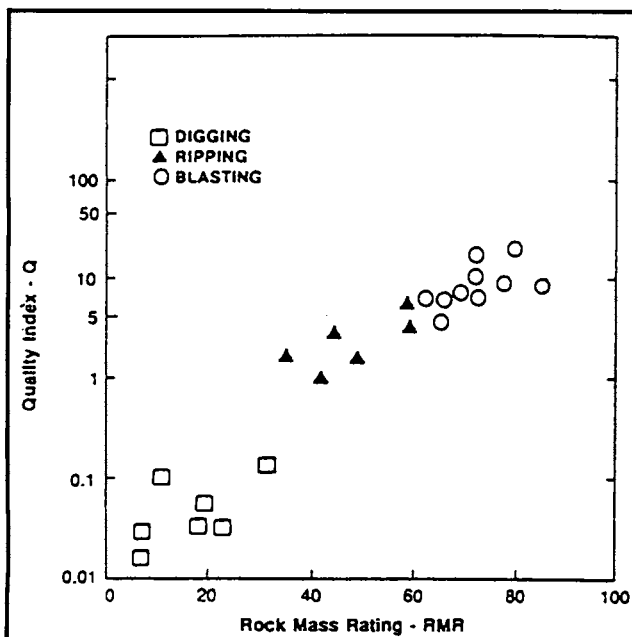

Figure 4. Rock mass quality classification diagram (based on RMR and Q indexes) depicting various excavation methods on sites (after Abdullatif and Cruden, 1983).

May 2003

Table 5.

Peck *et al.* (1974) suggested an empirical correlation between the allowable bearing pressure and the RQD of the rock mass. The correlation is shown in Figure 6 and is intended for a rock mass that is tightly jointed (i.e. fissures less than 0.1 to 0.2 mm). The RQD value used for this correction should be the average value obtained from within the depth equal to the width (B) of the footing. In the event that the rock between the contact surface to a depth of B/4 is lower quality than the lower RQD value for this layer should be used.

Pells and Turner (1978) has proposed a classification scheme for allowable bearing pressure in shale and sandstone. The allowable bearing pressure for each class of rock is presented in Table 6 for a limiting foundation displacement of 1% of the footing diameter. In the case of jointed rock mass, Sowers (1979) has proposed several possible mechanisms for bearing capacity failure (Fig. 7).

When the surface of the rock mass is of poor quality and requires a large footing, the foundation can be socketed into the rock mass. The rock socket may be designed to carry the loads in the following manner:

- end bearing only
- side resistance only or,
- combination of shaft and base resistance.

The unit end bearing resistance may be obtained using methods mentioned in foundation bearing directly on rock. The unit side resistance factor is usually correlated to uniaxial compressive strength of rock cores or the concrete strength. For rock cores, the values can be obtained directly from laboratory testing or by estimating the strength of the rock from accurate rock core logging. The curve relating these factors are presented by Williams and Pells (1981) in Figure 8. The adjustment factor is related to the RQD, demonstrating the reduction in the unit side resistance with increasing number of discontinuities.

## CONCLUSION

Natural rock masses are among the most variable geologic material. The variability of the engineering properties of rock could be due to one or more of the following factors; constituent minerals, degree of weathering, moisture content, bedding planes, joints, faults, etc. The engineering behaviour of rock mass, is often, also a function of scale, i.e. performance is dependent on the frequency of joints, joint spacing and characteristics of the joints. Furthermore, the durability of rocks must also be addressed when such geologic material is used for engineering purposes.

Accurate rock core logging can give preliminary or even detailed information of the above requirement for the use in design process in rock engineering as presented in this paper.

It should be recognized that good drilling require good supervision. This is best provided by frequent, or possibly full time attendance by the geologist at the drill rig.

REFERENCES

ABDULLATIF, O.M. AND CRUDEN, D.M., 1983. The relationship between rock mass quality and ease of excavation. *Bulletin of International Association of Engineering Geology*, 28, 183-187.

AASHTO (AMERICAN ASSOCIATION OF STATE HIGHWAY AND TRANSPORTATION OFFICIALS), 1988. *Manual on Subsurface Investigations*. American Association of State Highway and Transportation Officials Inc., Washington, USA.

ANON., 1970. The logging of rock cores for engineering purposes. *Quarterly Journal of Engineering Geology & Hydrogeology*,

3(1), 1-25.

ANON, 1981. Rock and soil description and classification for engineering geological mapping. Report by IAEG Commission on Engineering Geological Mapping. *Bull. Int. Assoc. of Engineering Geology*, 24, 235-274.

BARTON, N., 1983. Application of Q-system and index tests to estimate shear strength and deformability of rock masses. *Proceeding of International Symposium on Engineering Geology in Underground Construction*. A.A. Balkema, Boston, 51-70.

BARTON, N., LIEN, R. AND LUNDE, J, 1974. Engineering classification of rock masses for the design of tunnel support, *Rock Mechanics*,

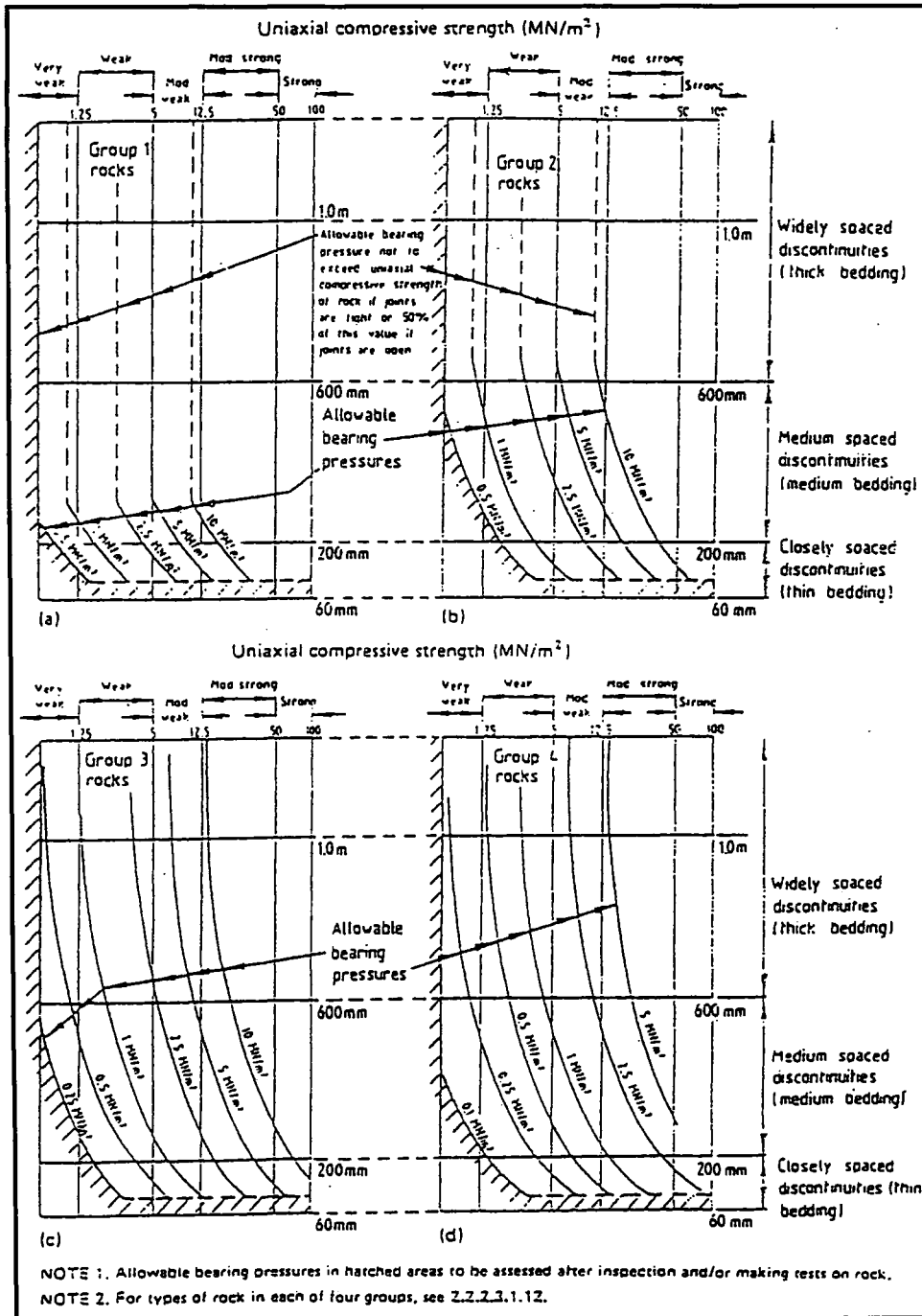
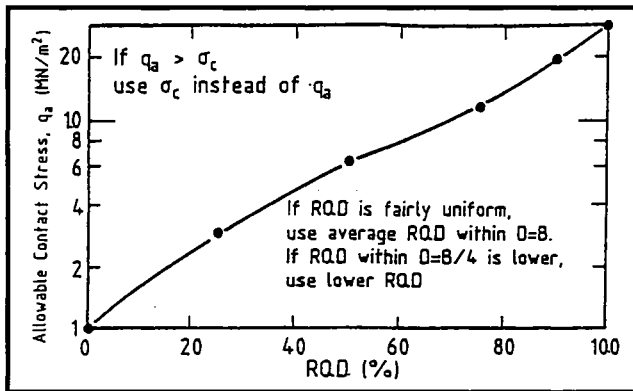

Figure 5. Allowable bearing pressure (after BSI, 1986).

**Table 4.** Presumed allowable bearing values (after BSI, 1986).

Presumed allowable bearing values under static loading (see 1.2.3 and 1.2.4)				
NOTE: These values are for preliminary design purposes only, and may need alteration upwards or downwards. No addition has been made for the depth of embedment of the foundation (see 2.1.2.3.2 and 2.1.2.3.3).				
Category	Types of rocks and soils	Presumed allowable bearing value		Remarks
		kN/m <sup>2</sup>	kg/cm <sup>2</sup> (ton/ft <sup>2</sup> )	
Rocks	Strong igneous and gneissic rocks in sound condition	10 000	100	These values are based on the assumption that the foundations are taken down to unweathered rock. For weak, weathered and broken rock, see 2.2.2.3.1, 12
	Strong limestones and strong sandstones	4 000	40	
	Schists and slates	3 000	30	
	Strong shales, strong mudstones and strong siltstones	2 000	20	
Non-cohesive soils	Dense gravel, or dense sand and gravel	> 600	> 6	Width of foundation not less than 1 m. Groundwater level assumed to be a depth not less than below the base of the foundation. For effect of relative density and groundwater level, see 2.2.2.3.2
	Medium dense gravel, or medium dense sand and gravel	< 200 to 600	< 2 to 6	
	Loose gravel, or loose sand and gravel	< 200	< 2	
	Compact sand	> 300	> 3	
	Medium dense sand	100 to 300	1 to 3	
	Loose sand	< 100	< 1	
Cohesive soils	Very stiff boulder clays and hard clays	300 to 600	3 to 6	Group 3 is susceptible to long-term consolidation settlement (see 2.1.2.3.3). For consistencies of clays, see table 5
	Stiff clays	150 to 300	1.5 to 3	
	Firm clays	75 to 150	0.75 to 1.5	
	Soft clays and silts	< 75	< 0.75	
	Very soft clays and silts	Not applicable		
Peat and organic soils	Not applicable		See 2.2.2.3.4	
Made ground or fill	Not applicable		See 2.2.2.3.5	
107.23 kN/m <sup>2</sup> = 1.094 kg/cm <sup>2</sup> = 1 ton/ft <sup>2</sup>				



**Figure 6.** Allowable bearing stress on jointed rock (after Peck *et al.*, 1974).

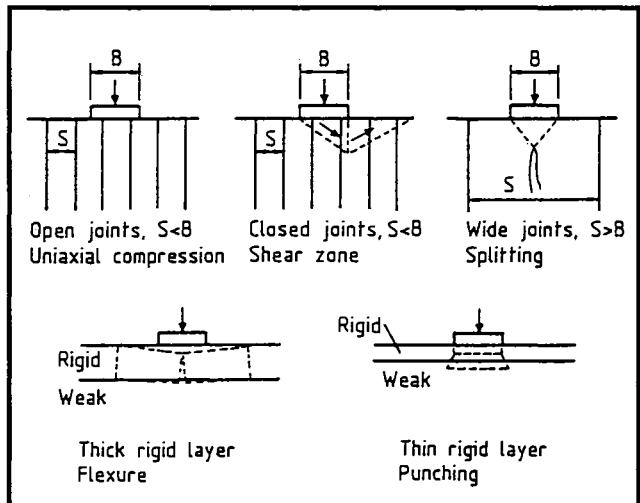

**Figure 7.** Bearing capacity failure modes (after Sowers, 1979).

Table 5. Rock group classification (after BSI, 1986).

The four rock groups have been given the following modulus ratios.

Group 1: 600  
Group 2: 300  
Group 3: 150  
Group 4: 75

These ratios are considered to be conservative.

NOTE. The calculation of allowable bearing pressure given in figure 1 assumes that  $E_m$  is constant with depth and that the rock layer is infinitely thick. This can lead to large errors in the calculated settlement if  $E_m$  varies or the rock layer is thin. A method of calculation which takes account of the variation of  $E_m$  and finite layer thickness is given in Meigh (1976).

Grouping of weak and broken rocks	
Group	Type of rock
1	Pure limestones and dolomites Carbonate sandstones of low porosity
2	Igneous Oolitic and marly limestones Well cemented sandstones Indurated carbonate mudstones Metamorphic rocks, including slates and schists (flat cleavage/foliation)
3	Very marly limestones Poorly cemented sandstones Cemented mudstones and shales Slates and schists (steep cleavage/foliation)
4	Uncemented mudstones and shales

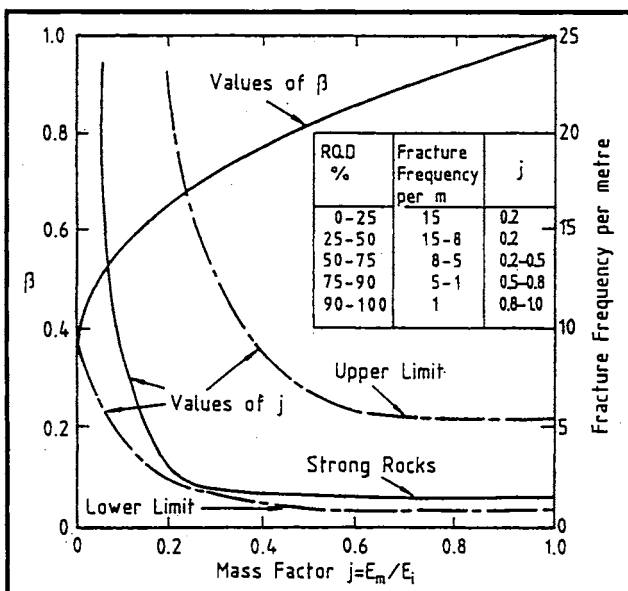

Figure 8. Mass factor, b (after Williams and Pells, 1981).

6, 183-236.

BIENIAWSKI, Z.T., 1973. Engineering classification of jointed rock masses. *Transcript South African Institution of Civil Engineers*, 15, 335-344.

BIENIAWSKI, Z.T., 1976. Rock mass classifications in rock engineering. *Proceed. Conf. Exploration for Rock Engineering, Johannesburg*, 1, 97-106.

BIENIAWSKI, Z.T., 1978. Determining rock mass deformability – experience from case histories, *International J. Rock Mechanics and Mining Sc.* 15, 237-247.

BIENIAWSKI, Z.T., 1989. *Engineering Rock Mass Classifications*. John Wiley & Sons, New York, 251p.

BRACE, W.F. AND RILEY, D.K., 1972. Static uniaxial deformation of 15 rocks to 30kb. *International J. Rock Mechanics & Mining Sc.*, 9, 271-288.

BSI (BRITISH STANDARDS INSTITUTION), 1981. *BS5930: Code of Practice for Site Investigation*, British Standard Institution, London.

BSI (BRITISH STANDARDS INSTITUTION), 1986. *BS8004: Code of Practice for Foundations*, British standard Institution, London.

BSI (BRITISH STANDARDS INSTITUTION), 1999. *BS5930: Code of Practice for Site Investigations*, British Standard Institution, London.

CLARK, S.P. (Ed.), 1966. *Handbook of Physical Constants. Geological society of America, Memoir 97*.

DEERE, D.U. AND DEERE, D.W., 1988. The RQD index in practice, *Proceeding of Symposium on Rock Classification for Engineering Purposes. ASTM special technical publication 984*, Philadelphia, 91-101.

DEERE, D.U., HENDRON, A.J., PATTON, F.D. AND CORDING, E.J., 1967. Design of surface and near surface construction in rock. *Proceeding of 8th US Symposium of Rock Mechanics*. AIME, New York, 237-302.

GCO (GEOTECHNICAL CONTROL OFFICE), 1988. *Guide to Soil and Rock Descriptions - Geoguide 3*. Geotechnical Control Office, Hong Kong, 189p.

HOEK, E. AND BRAY, J., 1977. *Rock Slope Engineering, 2nd Edition*. IMM, London, 402p.

HOEK, E., AND BROWN, E.T., 1988. The Hoek-Brown failure criterion — a 1988 update. *Proceeding of 15th Canadian Rock Mechanics Symposium*, University of Toronto, Canada.

IBRAHIM KOMOO, 1989. Engineering properties of the igneous rocks in Peninsular Malaysia. *Proceeding of Regional Conference on Geology, Mineral and Hydrothermal Resources in Southeast Asia, Jakarta*, 445-458.

ISRM (INTERNATIONAL SOCIETY OF ROCK MECHANICS), 1978. Suggested methods for the quantitative description of discontinuities in rock mass. *International J. Rock Mechanics and Mining Sc. & Geomechanics*, 15(6), 319-368. Pergamon Press, London.

ISRM (INTERNATIONAL SOCIETY OF ROCK MECHANICS), 1981. Basic geotechnical description of rock masses, *International J. Rock Mechanics and Mining S. & Geomechanics Abstract*, 18, 85-110. Pergamon Press, London.

KIRSTEN, H.A.D., 1982. A classification system for excavation in natural materials. *Transcript of Civil Engineers, South Africa*, 293-307.

LAUBSCHER, D.H., 1984. Design aspects and effectiveness of support systems in different mining conditions, *Transcript of Institution of Mining and Metallurgy*, 93, A70-A81.

NORBURY, D.R., CHILD, G.H. AND SPINK, T.W., 1986. A critical review of section 8 (BS5930: 1981) - Soil and rock descriptions



**Table 6.** Design values for shale and sandstone (after Pells and Turner, 1978).

DESIGN VALUES FOR FOUNDATIONS ON SANDSTONE									
CLASS	GENERAL DESCRIPTION AND FIELD GUIDE	SATURATED UNCONFINED COMPRESSION STRENGTH, $q_u$	FRACTURING	ALLOWABLE DEFECTS	END BEARING PRESSURE	SHAFT ADHESION	$\frac{E_{\text{rock}}}{E_{\text{core}}}$	Typical $E_{\text{rock}}$ MPa	MINIMUM INVESTIGATION OR PROVING TECHNIQUES
I	Strong sandstones, core sections of 50mm dia cannot be broken by hand and can be only slightly scratched with a steel knife.	> 24 MPa	Slightly fractured or unbroken	1.50%	Max. 12 MPa	0.05 $f_c$	0.9	> 2000	Comprehensive site investigation sufficient to define seams 5 layers of rock - cored boreholes on a minimum 10m grid spacing or cored boxes at not less than 50V of footing  Jackhammer holes a spoon testing at the remainder
II	Medium to strong sandstone - core sections can be broken by hand with difficulty and lightly scored with a steel knife	12 - 24 MPa	Slightly fractured	3%	6 MPa or 0.5 $q_u$ Max. 10 MPa	0.05 or 0.05 $q_u$ Max. 1200 kPa	0.7	900 - 3000	
III	Medium strong sandstone - core sections can be broken easily by hand and readily scored with a steel knife	7 - 12 MPa	Fractured	5%	3.5 MPa or 0.5 $q_u$ Max. 6.0 MPa	0.05 $q_u$ Max. 600 kPa	0.5	350 - 1200	Site investigation to include at least 4 cored boreholes and jackhammer holes and spoon testing or cores in at least 1/3 of footings
IV	Weak sandstone - core sections break easily and may be heavily scored or cut with a steel knife	2 - 7 MPa	Fractured	10%	1 MPa or 0.5 $q_u$ Max. 3.5 MPa	0.05 $q_u$ Max. 350 kPa	0.4	100 - 700	Engineer's site inspection with at least 2 cored boreholes
V	Very weak sandstone - rock structure is evident but frequent zones of sugary sandstone - crumbled by hand	Not normally measurable	Highly fractured or fragmented	-	0.8 - 1.0 MPa	75 - 150 kPa	-	50 - 200	
DESIGN VALUES FOR FOUNDATIONS ON SHALE									
CLASS	GENERAL DESCRIPTION & FIELD GUIDE	UNCONFINED COMPRESSION STRENGTH $q_u$	FRACTURING	ALLOABLE DEFECTS	END BEARING PRESSURE	SHAFT ADHESION	$\frac{E_{\text{rock}}}{E_{\text{core}}}$	Typical $E_{\text{rock}}$ MPa	MINIMUM INVESTIGATION OR PROVING TECHNIQUES
I	Strong shale - core sections can only be slightly scratched with steel knife	> 16 MPa	Slightly to fractured	2%	Max. 8 MPa	0.05 $f_c$	0.9	> 2000	Comprehensive site investigation sufficient to define seams 5 layers of rock - cored boreholes on a minimum 10m grid spacing or cored holes at not less than 50% of footings. Jackhammer holes and spoon testing at the remainder.
II	Medium to strong shale - core sections can be scored with steel knife	7 - 16 MPa	Fractured	4%	3.5 MPa or 0.5 $q_u$ Max. 6 MPa	350 kPa or 0.05 $q_u$ Max. 800 kPa	0.7	700 - 2000	Site investigation to include at least 4 cored boreholes. Jackhammer holes and spoon testing or cores in at least 1/3 of footings.
III	Medium strong shale - core sections can be deeply scored with a steel knife	2 - 7 MPa	Fractured to highly fractured	3%	1 MPa or 0.5 $q_u$ Max. 3.5 MPa	150 kPa or 0.05 $q_u$ Max. 350 kPa	0.5	200 - 1200	Engineers site inspection to include at least 2 cored boreholes
IV	Weak shale - core sections can be heavily scored or cut with steel knife - alternatively interbedded medium strong and very weak shale	Not normally measurable	Highly fractured or fragmented	25%	1.0 MPa	150 + kPa	0.4	100 - 500	
V	Mainly shaly clay - hard clay with thin tones of weak shales	Not normally measurable	Highly fractured or fragmented	-	0.7 MPa	50 - + 100 kPa	-	50 - 300	Engineer's site inspection

- see text for definitions and explanations; + values may have to be reduced because of smear

- In: Hawkins, A.B. (Ed.), *Site Investigation Practice: Assessing BS5930*. The Geological Society, London, 331-342.
- Ooi, L.H., 2002. Introduction to Rock Mechanics, *Course Note of Tripartite Meeting and Technical Course in Geotechnical Engineering on 27/6/2002*, IEM, Johor Bahru.
- PECK, R.B., HANSON, W.E. AND THORNBURN, T.H., 1974. *Foundation Engineering, 2<sup>nd</sup> Edition*. John Wiley and Sons, New York, 514p.
- PELLS, P.J.N. AND TURNER, R.M., 1978. End bearing on rock with particular reference to sandstone. *Proceeding of International conference on Structural Foundation on Rock, Sydney, Volume I*. A.A. Balkema, Rotterdam, 181-190.
- ROBERTSON, A.M., 1988. Estimating weak rock strength, *AIME-SME Annual Meeting*. Phoenix, Arizona, 88-145.
- ROMANA, M., 1985. New adjustment rating for application of the Bieniawski classification of slopes. *Proceeding of International Symposium on Rock Mechanics in Mining and Civil Works*. ISRM, Zacatecas, Mexico, 59-63.
- SERAFIM, J.L. AND PEREIRA, J.P., 1983. Considerations of the geomechanical classification of Bieniawski. *Proceeding on International Symposium on Engineering Geology in Underground Construction*. A.A. Balkema, Boston, 33-43.
- SINGH, R.N., DENBY, B., EGRETLI, I. AND PATHON, A.G., 1986. Assessment of ground rippability in opencast mining operations. *Mining Department Magazine, University of Nottingham*, 38, 21-34.
- SMITH, H.J., 1986. Estimating rippability by rock mass classification. *Proceeding of 27<sup>th</sup> US Symposium on Rock Mechanics*. AIME, New York, 443-448.
- SOWERS, G.F., 1979. *Geotechnical Engineering, 4<sup>th</sup> Edition*. MacMillan Publishing Co., New York, 621p.
- STILLE, H., GROTH, T. AND FREDRIKSSON, 1982. FEM analysis of rock mechanics problems by JOBFEM. *Swedish Rock Engineering Research Foundation Publication*, 307, 1-8.
- USACE (UNITED STATES ARMY CORPS OF ENGINEERS), 2001. *Geotechnical Investigations*. Engineers Manual,